



CANBUILT MFG.

Toll-Free in Canada: 1-888-607-2926 Phone: 416-749-6555 Fax: 416-749-7597
Email: sales@canbuilt.com Website: www.canbuilt.com

103 Milvan Drive,
Toronto, Ontario,
Canada, M9L 1Z7

4400 LB MOBILE CRANE

Model # 4400P

FEATURES:

- Provides unmatched stability when under load, yet takes up much less space when not in use. Front legs telescope to provide greater load stability
- 8 Ton Air / Hydraulic power with Manual override. (Can be used either with air or manual pump) Hook and chain excluded.
- Front legs can be reversed to telescope back wards, and allow counter balance to be introduced to rear of crane for picking objects out of a well, below grade or where legs get in the way
- 6" swivel front wheels, 4 rear wheels allow easy movement around the shop. "Canadian Made Quality"

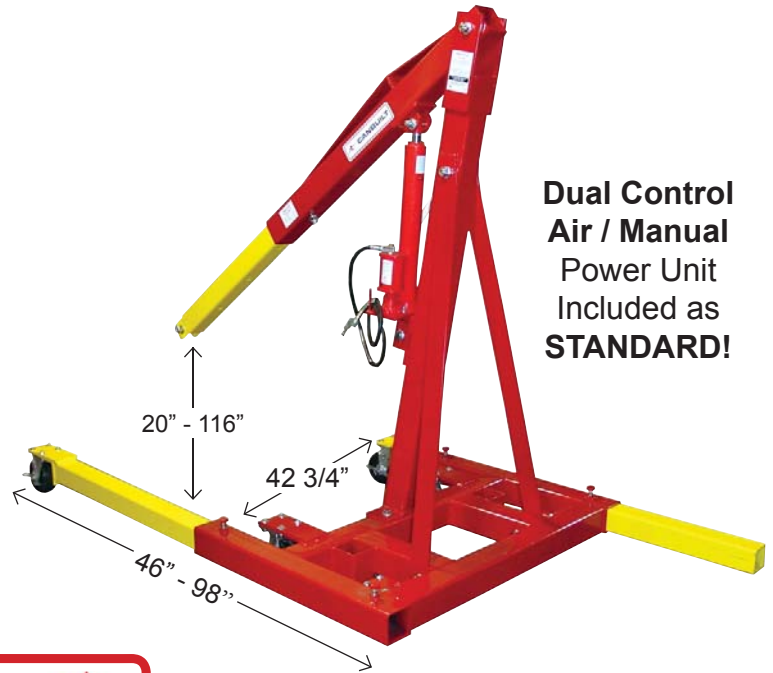

**Dual Control
Air / Manual
Power Unit
Included as
STANDARD!**

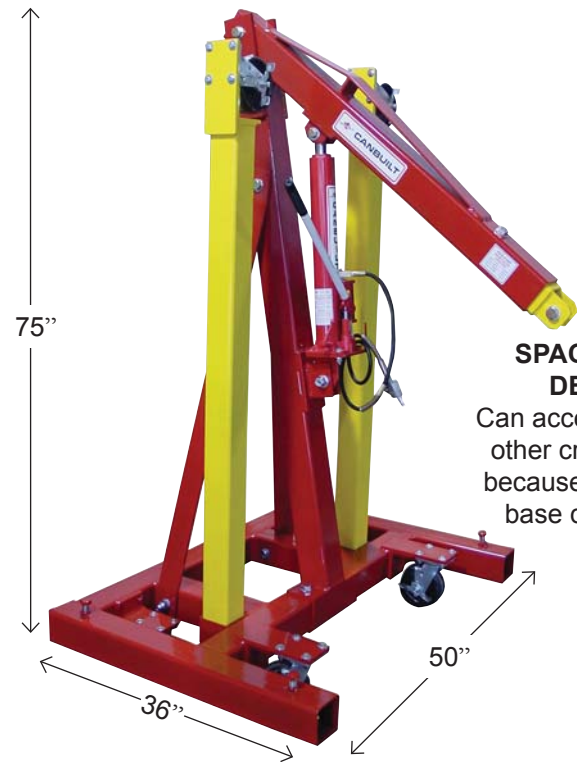

SPACE SAVER DESIGN !

Can access areas that other cranes cannot because of 36" x 50" base dimensions.

**Full Swivel
Locking Wheels !**



**45 Gal. Drums can
provide counter balance
when legs are
telescoped backwards**

Boom Capacities & Reach		
Position 1 (Retracted)	@ 32" Reach	4400 lbs
Position 2	@ 42" Reach	3400 lbs
Position 3	@ 52" Reach	2000 lbs
Position 4 (Fully extended)	@ 60" Reach	1400 lbs

Model	Capacity	Overall Height	Base Width	Base Length Min Max	Reach	Boom Height	Shipping Weight
4400P	4400 LBS	75"	50"	46" 98"	32" - 60"	102" - 116"	950 lbs

QUALITY • PERFORMANCE • LONGEVITY